

**DIVISION: 07 00 00 – THERMAL AND MOISTURE PROTECTION**  
**Section: 07 45 00 – Fiber-reinforced Cementitious Panels**

**REPORT HOLDER:**  
Nichiha USA Inc.  
6465 E. Johns Crossing, Suite 250  
Johns Creek, Georgia 30097  
[www.nichiha.com](http://www.nichiha.com)

**REPORT SUBJECT:**  
Nichiha™ Architectural Wall Panels (AWP) and Sierra/  
Savannah Lap Siding

### 1.0 SCOPE OF EVALUATION

**1.1** This Research Report addresses compliance with the following Codes:

- 2024, 2021, 2018, 2015 *International Building Code*® (IBC)
- 2024, 2021, 2018, 2015 *International Residential Code*® (IRC)
- 2024 *International Wildland-Urban Interface Code* (IWUIC)
- 2023, 2020 *Florida Building Code* (FBC) (see Section 9)
- 2025, 2022 *California Building Code* (CBC) (see Section 9)

NOTE: This report references the most recent edition of the Codes cited. Section numbers from earlier editions of the Codes may differ.

**1.2** The Nichiha Fiber-reinforced cement AWP and Lap Siding described in this report have been evaluated for the following properties (see Table 1):

- Physical properties
- Surface burning characteristics
- Ignition resistance
- Wind resistance
- Fire resistance

**1.3** The Nichiha AWP and Lap Siding have been evaluated for the following uses (see Table 2):

- Use as an alternative to the exterior wall covering described in IBC Section 1403.10 and IRC Section R703.10
- Use on exterior walls permitted to be of Types I through IV construction
- Use on exterior walls permitted to be of Type V construction
- Use on exterior walls of buildings within wildland-urban interface areas where ignition-resistant materials are required
- Use as interior wall finish under IBC Section 803.1.1 and IRC R302.9.4 (AWP Wall Panel only)

### 2.0 STATEMENT OF COMPLIANCE

The Nichiha AWP and Lap Siding recognized in this report comply with the Codes listed in Section 1.1, for the properties stated in Section 1.2, and uses stated in Section 1.3, when installed as described in this report, including the Conditions of Use stated in Section 6.0.

**2.1 2024 IBC and IRC Evaluation Reports:** The Intertek CCRR is an *Evaluation Report* for approval of an alternate material, design, or method of construction in accordance with Section 104.2.3.6.1 of the 2024 IBC and Section R104.2.2.6.1 of the 2024 IRC.

### 3.0 DESCRIPTION

**3.1 Nichiha AWP and Lap Siding:** The AWP and Lap Siding are used as exterior cladding. A description of the panels and lap siding, their dimensions, and their intended application, is in Table 2.

### 4.0 PERFORMANCE CHARACTERISTICS

**4.1 Physical Properties:** The AWP and Lap Siding have been tested in accordance with, and found to comply with, the performance requirements of ASTM C1186, Type A, Grade II.



**4.2 Surface Burning Characteristics:** The AWP and Lap Siding have a flame spread index of 0 and a smoke-developed index of 5, when tested in accordance with ASTM E84.

**4.3 Ignition Resistant Building Materials:** The AWP and Lap Siding comply with IWUIC and CWUIC Section 503.2.4 as ignition resistant building materials.

**4.4 Wind Resistance:** The maximum allowable wind pressure for the AWP and Lap Siding is described in Tables 3, 5, 7, and 8.

**4.5 Fire Resistance:** The minimum 5/8 in. thick AWP or Lap Siding, when applied over a loadbearing or nonloadbearing 1 hour fire-resistance rated base wall assembly, will not reduce the fire-resistance rating of that wall assembly.

## 5.0 INSTALLATION

**5.1 General:** The AWP and Lap Siding must be installed in accordance with the Nichiha USA Inc. published installation instructions, the applicable Code, and this Research Report. A copy of the manufacturer's instructions must be available on the jobsite during installation.

**5.2 Application:** Under the IBC, the AWP and Lap Siding must be installed over a water-resistive barrier complying with Sections 1403.2 and 1402.5, and must be attached as described for the specific assembly in Tables 3, 5, and 7.

Under the IRC, the AWP and Lap Siding must be installed over a water-resistive barrier complying with Section R703.2. The AWP and Lap Siding must be installed as described in Tables 3 and 5.

**5.3 Use on Exterior Walls of Types I, II, III, and IV Construction:** When used on exterior walls of Types I, II, III, or IV construction that are greater than 40 feet in height, the AWP assembly must comply with IBC Section 1402.5. Intertek Design Listings [NUI/FRCP 30-01](#) and [NUI/FRCP 30-02](#) describe the AWP assemblies tested and certified by Intertek as complying with NFPA 285.

The AWP may be installed on buildings with a separation distance less than 5 feet in accordance with IBC Section 1405.1.1.1, based on testing in accordance with NFPA 268.

**5.4 Use in Fire-resistance Rated Wall Construction:** The AWP and Lap Siding are permitted to be installed on the exterior of wall assemblies complying with IBC Section 703.2. The length of the fasteners utilized to attach the AWP Steel Clips to the framing, as described in Tables 3, 4 and 8, must be increased by the thickness of the layers of the exterior fire-resistance rated wall construction. The length of the fasteners utilized to attach the Lap Siding to the framing, as described in Tables 5, 6, and 8, must be increased by the thickness of the layers of the exterior fire-resistance rated wall construction.

**5.5 Use as Interior Wall Finish:** The AWP panels are permitted to be installed as Class A interior finish materials complying with IBC Section 803.1.1 and IRC Section R302.9.4.

## 6.0 CONDITIONS OF USE

**6.1** Installation must comply with this Research Report, the manufacturer's published installation instructions, and the applicable Code. In the event of a conflict, this report governs.

**6.2** When allowable wind speed is determined in accordance with Tables 3, 5, and 7, the allowable wind speed must be equal to or greater than the design wind speed calculated in accordance with the applicable Code.

**6.3** Use in Types I, II, III, or IV construction must be as described in Section 5.3.

**6.4** Use in fire-resistance rated exterior wall construction must be as described in Section 5.4.

**6.5** The Nichiha AWP and Lap Siding are produced under a quality control program with inspections by Intertek Testing Services NA, Inc.

## 7.0 SUPPORTING EVIDENCE

**7.1** Reports of tests demonstrating compliance with ASTM C1186-2008(2016), ASTM E84-21a, ASTM E330-14(2021), ASTM E2768-11(2018), NFPA 268-22, NFPA 285-23, NFPA 286-24, TAS 202-94, and TAS 203-94.

**7.2** Data in accordance with applicable sections of ICC-ES Acceptance Criteria for Fiber Cement Siding Used as Exterior Wall Siding (AC90), approved October 2018.



Intertek

130 Derry Court • York • Pennsylvania • 17406  
[intertek.com/building](http://intertek.com/building)



PCA-101



**7.3** Intertek Listing Report "Nichiha Architectural Wall Panels and Lap Siding" on the [Intertek Directory of Building Products](#).

**7.4** Miami-Dade Checklist #0215 for fiber cement siding and soffits (Note #1), dated 08-01-17.

**7.5** Documentation of an Intertek approved quality control system for the manufacturing of products recognized in this report.

## 8.0 IDENTIFICATION

The Nichiha AWP and Lap Siding are identified with the Nichiha USA Inc. name and address, the product name, the Intertek Mark as shown below, and the Code Compliance Research Report number (CCRR-0299).



## 9.0 OTHER CODES

**9.1 California Building Code:** The AWP and Lap Siding, described in Sections 2.0 through 7.0 of this report, comply with the *California Building Code* and *California Residential Code*, subject to the conditions noted in Section 6.0 of this report. Section numbers for the 2025 *CBC – Building and Residential* correspond to the 2024 IBC and IRC section numbers.

- The AWP and Lap Siding are ignition resistant materials complying with California WUIC 503.2.4 and may be used where an exterior covering is required by California WUIC Section 504.5.
- When the AWP and Lap Siding are used in Types I, II, III, or IV construction, the wall coverings shall comply with Section 5.3.

- The AWP panels are permitted for use as interior wall finish materials under CBC Section 803.1.1 and CRC R302.9.

**9.2 Florida Building Code:** The Nichiha AWP and Lap Siding, described in Sections 2.0 through 7.0 of this report, comply with the *Florida Building Code – Building*, and *Florida Building Code – Residential*, subject to the following conditions:

- Use of the AWP and Lap Siding in Types I, II, III, or IV construction is as permitted in *Florida Building Code – Building*, Section 1406.2.1, when installed as described in Section 5.3.
- Use of the AWP and Lap Siding for compliance with the High-Velocity Hurricane Zone (HVHZ) provisions of the *Florida Building Code – Building* and the *Florida Building Code – Residential* is described in Table 8 of this Research Report.
- In HVHZ applications, the AWP and Lap Siding must be installed over CBS construction or 5/8 in. (5-Ply) plywood supported by 2x studs or 2 × 6-18 gauge metal studs, spaced at 16 inches on center.
- The AWP panels are permitted for use as interior wall finish materials under *FBC - Building* Section 803.1.2 and *FBC - Residential* R302.9.
- Intertek is an approved *evaluation entity and quality assurance entity* pursuant to Florida Statute 553.842 – *Product Evaluation and Approval*.

## 10.0 CODE COMPLIANCE RESEARCH REPORT USE

**10.1** Approval of building products and/or materials can only be granted by a building official having legal authority in the specific jurisdiction where approval is sought.

**10.2** Code Compliance Research Reports shall not be used in any manner that implies an endorsement of the product by Intertek.

**10.3** Reference to the <https://bpdirectory.intertek.com> is recommended to ascertain the current version and status of this report.

This Code Compliance Research Report ("Report") is for the exclusive use of Intertek's Client and is provided pursuant to the agreement between Intertek and its Client. Intertek's responsibility and liability are limited to the terms and conditions of the agreement. Intertek assumes no liability to any party, other than to the Client in accordance with the agreement, for any loss, expense or damage occasioned by the use of this Report. Only the Client is authorized to permit copying or distribution of this Report and then only in its entirety, and the Client shall not use the Report in a misleading manner. Client further agrees and understands that reliance upon the Report is limited to the representations made therein. The Report is not an endorsement or recommendation for use of the subject and/or product described herein. This Report is not the Intertek Listing Report covering the subject product and utilized for Intertek Certification and this Report does not represent authorization for the use of any Intertek certification marks. Any use of the Intertek name or one of its marks for the sale or advertisement of the tested material, product or service must first be approved in writing by Intertek.





TABLE 1 – PROPERTIES EVALUATED

PROPERTY	APPLICABLE CODE SECTIONS <sup>1</sup>						
	IBC	IRC	FBC – Building	FBC – Residential	CBC	CRC	IWUIC & CWUIC
Physical properties	1403.9	R703.10	1404.10	R703.10	1403.9	R703.10	NA
Surface burning characteristics	1403.9	R703.10	1404.10	R703.10	1403.9	R703.10	NA
Ignition resistant material	NA	NA	NA	NA	NA	NA	503.2.4
Wind resistance	1404.17	R703.16	1405.16	703.1.2	1404.17	R703.16	NA
Weather resistance	1403.2	R703.2	1404.2	R703.2	1403.2	R703.2	NA
Types I – IV construction	602 1402.5	NA	1403.5 & 1406.2.1	NA	602 1402.5	NA	NA
Installation over foam plastic insulation	2603.5	NA	2603.5	NA	2603.5	NA	NA
Interior Application	803.1.1	R302.9.4	803.1.2	R302.9	803.1.1	R302.9	NA

<sup>1</sup> Section numbers may be different for earlier versions of the International, Florida, and California Codes.

TABLE 2 – NICHHA ARCHITECTURAL WALL PANELS AND LAP SIDING DESCRIPTIONS

Product Name	Nominal Thickness (in.)	Siding Dimensions (in.)	Intended Use
AWP 3030	5/8	Width: 18 Length: 119-5/16	Panel siding <sup>†</sup>
AWP 1818	5/8, 3/4, 7/8	Width: 18 Length: 71-9/16	Panel siding <sup>†</sup>
Sierra Premium Shake Board	1/2	Width: 8-7/8 Length: 112	Lap Siding <sup>†</sup>
Savannah Smooth Board	1/2	Width: 6-1/4, 7-1/4, 8-1/4 Length: 112	Lap Siding <sup>†</sup>

<sup>†</sup>Panels may be installed in either a vertical or a horizontal orientation.

<sup>‡</sup>Panels and lap siding must be installed in a horizontal orientation only.



TABLE 3 – ARCHITECTURAL WALL PANEL DESIGN LOADS FOR NEGATIVE ASTM E330 TRANSVERSE LOAD<sup>5,6</sup>

Nominal Panel Thickness (in.)	Panel Orientation	Tested Framing Material	Required Clip System <sup>3,4</sup>	Minimum Clip Fasteners into Framing <sup>7</sup>	Allowable Design Pressure (psf)	Required Fastener Withdrawal Capacity (lbs) <sup>1,2</sup>
5/8	Horizontal	18-ga Steel Studs	JEL778 Steel Clip	16 in. spacing	58.0	145.1
		16-ga Steel Studs	JEL778 Steel Clip	16 in. spacing	72.6	181.5
		2 x 6 D.F. Studs	JEL778 Steel Clip	16 in. spacing	63.6	158.9
	Vertical	7/16 in. APA Rated OSB	JEL778 Steel Clip	4 equally spaced screws per clip	57.6	63.0
		16-ga Steel Studs (18 in. oc) 5/8 in. Glass Mat Gypsum Sheathing	JEL778 Steel Clip	4 equally spaced screws per clip	92.9	101.6
		2 x 6 D.F. Studs 3/4 in. APA Plywood	JEL778 Steel Clip	4 equally spaced screws per clip	89.5	97.9
3/4	Horizontal	18-ga Steel Studs	JEL788 Steel Clip	16 in. spacing	58.0	145.1
7/8	Horizontal	18-ga Steel Studs	JEL 788 Steel Clip	16 in. spacing	58.0	145.1

## Notes:

- The required fastener withdrawal capacity is based upon 18 in. deep panels and the corresponding clip/fastener spacing. The calculated value indicates the fastener withdrawal capacity required to ensure the full siding capacity is utilized. Any fastener to frame/sheathing combination that meets the required fastener withdrawal capacity, has a minimum head diameter of 0.375 in., and has a minimum shank diameter of 0.134 in. may be used to anchor the clip system to the wall.
- The required fastener withdrawal capacity may be reduced by the ratio of the Actual Design Pressure to the Allowable Design Pressure:

$$\text{Reduced Required Withdrawal Capacity} = \text{Required Withdrawal Capacity (from Table 2)} \times \frac{\text{Actual Design Pressure}}{\text{Allowable Design Pressure}}$$

- Refer to Table 4 for Nichiha Clip System Descriptions.
- Refer to Fig. 1 through Fig. 4 for Nichiha Clip System Details.
- Vertical panel installation is valid for 119-5/16 in. AWP 3030 product only.
- Reference Nichiha Installation Guidelines for proper installation procedure.
- Values for horizontal clip spacing are based on a minimum of 2 fasteners per clip. Values for vertical clip spacing are based on a minimum of 4 fasteners per clip.

TABLE 4 – CLIP SYSTEM SUMMARY<sup>1,2,6</sup>

Nominal Panel Thickness (in.)	Panel Orientation	Clip System <sup>4</sup>	Rainscreen Gap (mm)	Starter Track <sup>3,4</sup>	Panel Clip <sup>5</sup>		
					Part No.	Material <sup>3</sup>	Minimum Thickness (in)
5/8	Horizontal	JEL778 Steel Clip	10	FA700	JEL778	AISI/SAE 1015	0.047
	Vertical	JEL778 Steel Clip	10	FA710T	JEL778	AISI/SAE 1015	0.047
3/4	Horizontal	JEL788 Steel Clip	10	FA700	JEL788	AISI/SAE 1015	0.047
7/8	Horizontal	JEL788 Steel Clip	10	FA700	JEL788	AISI/SAE 1015	0.047

## Notes:

- Clip systems shall be used with the corresponding panel thickness and orientation shown in Tables 3 and 8 of this CCRR.
- Fasteners must have a minimum head diameter of 0.375 in., minimum shank diameter of 0.134 in., and be capable of resisting the withdrawal requirements indicated in Table 3 of this CCRR.
- All starter tracks and panel clips are manufactured using AISI/SAE 1015 (or better) steel with a minimum yield strength of 27,500 psi and minimum tensile strength of 50,000 psi.
- The starter track steel has a Galvalume™ coating.
- The panel clip steel has a ZAM® coating consisting of zinc, aluminum, and magnesium.



Intertek

130 Derry Court • York • Pennsylvania • 17406  
[intertek.com/building](http://intertek.com/building)



PCA-101

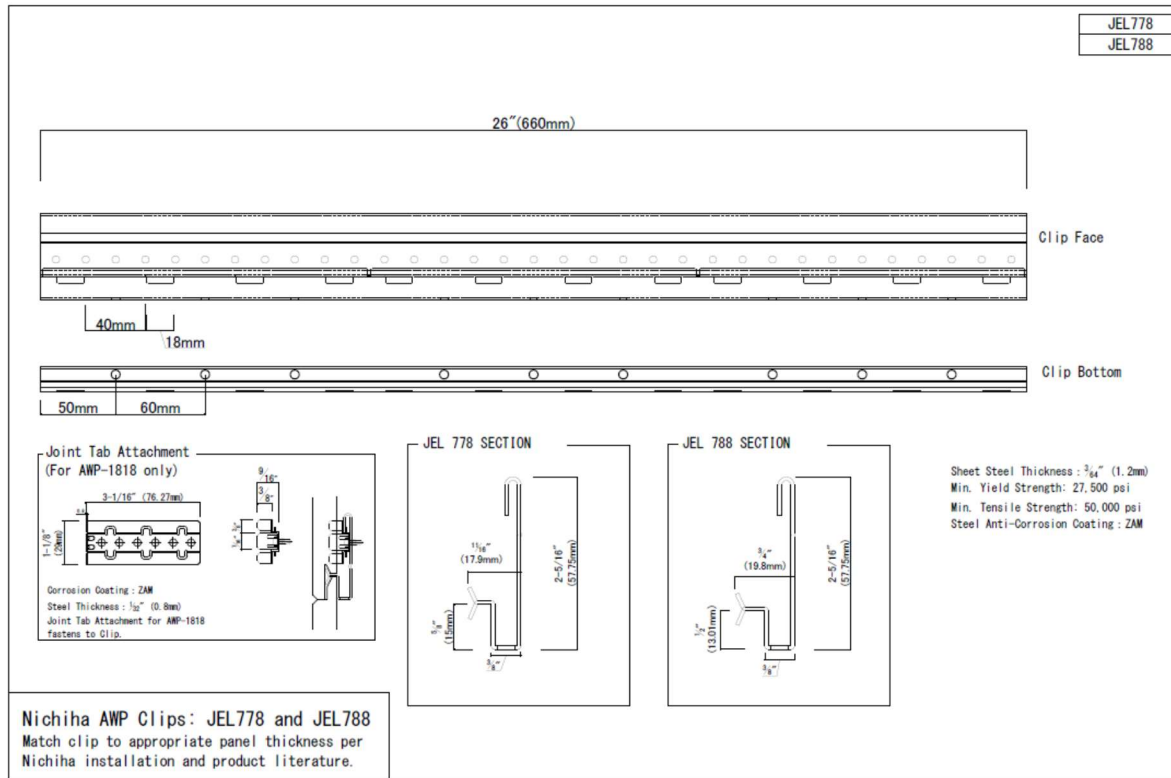

FIGURE 1 – PANEL CLIP DETAILS

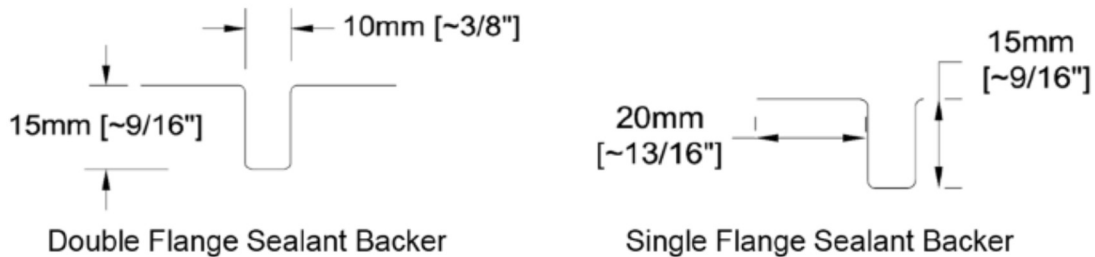

FIGURE 2 – SEALANT BACKER DETAILS

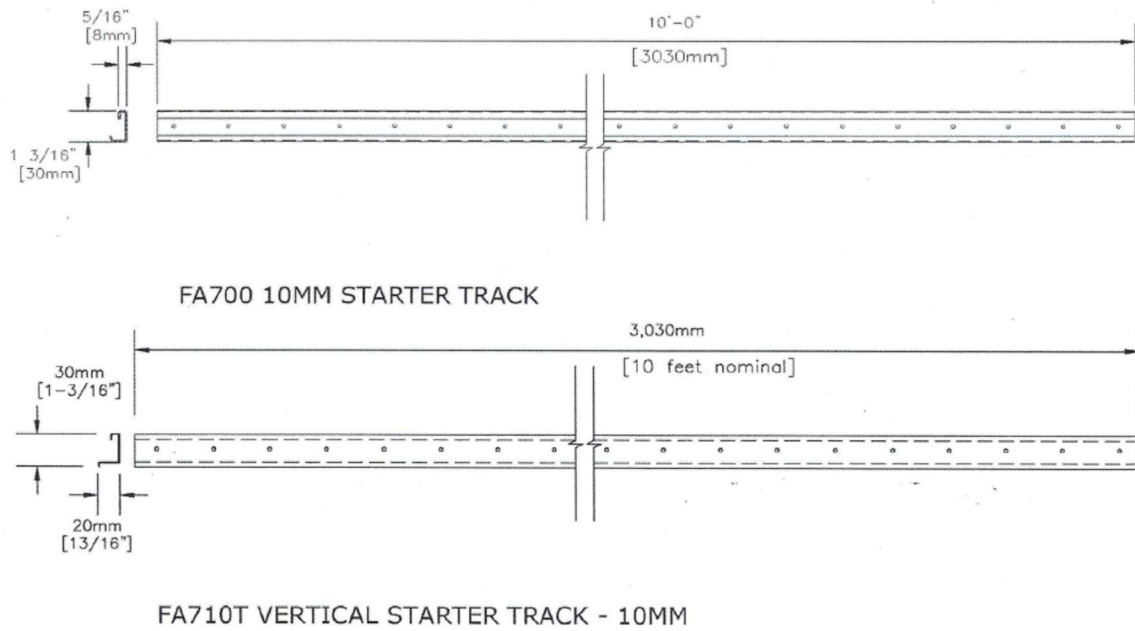

FIGURE 3 – STARTER TRACK DETAILS

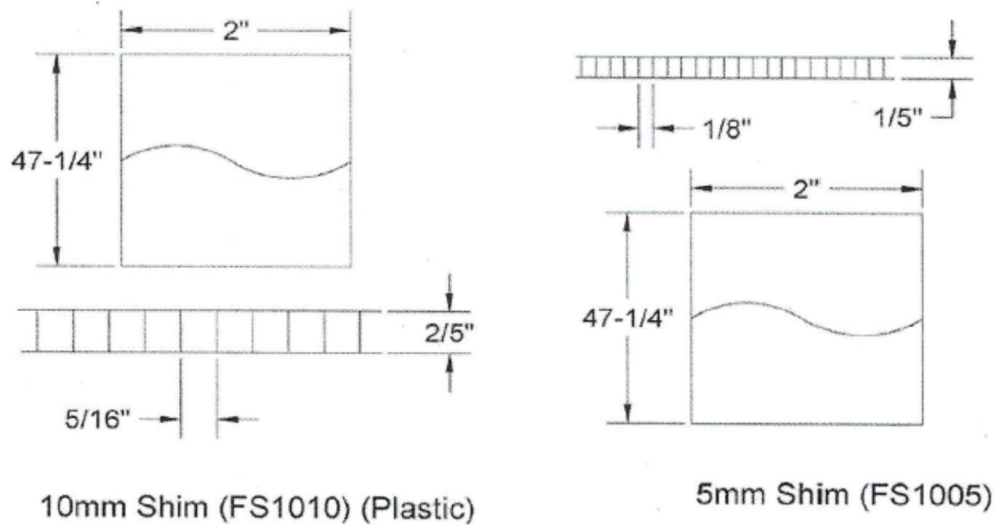

FIGURE 4 – CORRUGATED SHIM DETAILS



TABLE 5 – DESIGN LOADS FOR NEGATIVE TRANSVERSE WIND LOAD (SIERRA SHAKE & SAVANNAH SMOOTH)<sup>1,5,8</sup>

Siding Type	Siding Fastener (Corner) <sup>6</sup>	Siding Fastener (Field) <sup>6</sup>	Face/Blind	Effective Fastener Spacing (in.)		Framing Type <sup>9</sup>	Adjusted Allowable Pressure (psf) <sup>7</sup>	Building Height (ft)	ASCE 7-05 Basic Wind Speed (3s Gust) <sup>3</sup>			ASCE 7-10, -16, -22 Ultimate Wind Speed (3s Gust) <sup>4</sup>		
				Horizontal	Vertical				Exp B	Exp C	Exp D	Exp B	Exp C	Exp D
9 in. Sierra Premium Shake <sup>2</sup>	#8-18 ROCK-ON™ Screws	6d Ring Shank Double HD MAZE Coil Nail	Blind	16	8.875	DF @ 16 in. oc & 7/16 in. OSB	-24.0	15	100	91	--	129	117	106
								20	100	88	--	129	117	104
								25	100	86	--	129	111	102
								30	100	--	--	129	109	100
								40	96	--	--	124	106	--
								50	93	--	--	120	103	--
	60	91	--	--	117	101	--							
	#8-18 ROCK-ON™ Screws	#8-18 ROCK-ON™ Screws	Blind	16	8.875	DF @ 16 in. oc & 7/16 in. OSB	-49.4	15	143	130	118	185	168	152
								20	143	126	115	185	163	149
								25	143	124	113	185	160	146
								30	143	121	111	185	156	144
								40	137	118	109	178	152	140
								50	133	115	106	172	148	137
	60	130	113	105	168	146	135							
	#8-18 ROCK-ON™ Screws	Double HD MAZE Asphalt & Fiberglass Shingle Nail	Blind	8	8.875	DF @ 16 in. oc & 7/16 in. OSB	-41.8	15	132	120	109	170	154	140
								20	132	116	106	170	150	137
								25	132	114	104	170	147	135
								30	132	111	102	170	144	132
								40	126	108	100	163	140	129
								50	123	106	98	158	136	126
	60	120	104	96	154	134	124							
	#8-18 ROCK-ON™ Screws	#8-18 ROCK-ON™ Screws	Blind	8	8.875	DF @ 16 in. oc & 7/16 in. OSB	-82.6	15	170	168	153	210	210	197
								20	170	163	149	210	210	192
								25	170	160	146	210	206	189
30								170	157	144	210	202	186	
40								170	152	140	210	196	181	
50								170	148	137	210	192	178	
60	168	146	135	210	188	175								
#7 PrimeGuard SS Trim/Finish Grip Rite Screw	#7 PrimeGuard SS Trim/Finish Grip Rite Screw	Face	16	8.875	DF @ 16 in. oc & 7/16 in. OSB	-179.1	15	170	170	170	210	210	210	
							20	170	170	170	210	210	210	
							25	170	170	170	210	210	210	
							30	170	170	170	210	210	210	
							40	170	170	170	210	210	210	
							50	170	170	170	210	210	210	
60	170	170	170	210	210	210								

Notes:

1. Sierra Premium Shake and Savannah Smooth fiber-reinforced cement lap siding may only be installed on vertical walls.
2. Allowable pressures and wind speeds shown for 9" Sierra Premium Shake may be used to validate installations of 6-1/4 in., 7-1/4 in., & 8-1/4 in. Savannah Smooth installed with the same fastening/framing configuration shown in Table 5.
3. ASCE 7-05 Basic Wind Speeds are based upon occupancy category II, a wind directionality factor (Kd) equal to 0.85, an internal pressure coefficient (GCpi) equal to +/-0.18, and an external pressure coefficient (GCp) equal to -1.4. The effects of topographic features have not been considered and the wind speed has been limited to 170 mph.
4. ASCE 7-10, -16, -22 Ultimate Wind Speeds are based upon wind directionality factor (Kd) equal to 0.85, an internal pressure coefficient (GCpi) equal to +/-0.18, and an external pressure coefficient (GCp) equal to -1.4. Under ASCE 7-16 and -22, the wind speeds are based on Ke = 1.0. The effects of topographic features have not been considered and the wind speed has been limited to 210 mph.
5. The values in this table are based on testing per ASTM E330 and represent the allowable capacity of the siding to resist the wind pressures associated with the corresponding wind speed.
6. Fastener specifications for those used in testing are outlined in Table 6 of this CCRR. These specifications may be used by the designer of record to determine the acceptability of alternative fasteners.
7. Allowable design pressures in highlighted cells have been adjusted based on the listed allowable withdrawal capacity of the tested fastener.
8. Framing and bracing are beyond the scope of this evaluation report.
9. DF (Douglas Fir) framing material.



Intertek

130 Derry Court • York • Pennsylvania • 17406  
[intertek.com/building](http://intertek.com/building)



PCA-101



**TABLE 6 – SPECIFICATIONS OF TESTED FASTENERS FOR SIERRA PREMIUM AND SAVANNAH SMOOTH LAP SIDING**

Siding Fastener	Length (in.)	Head Diameter (in.)	Shank Diameter (in.)	Material <sup>1,2</sup>	Siding Type <sup>3</sup>	Minimum Fastener Penetration into Material (in.)	Fastener Withdrawal Value (lbs)
6d Ring Shake Double HD MAZE Coil Nail	2	0.233	0.105	DF w/7/16 in. OSB	Sierra Premium or Savannah Smooth (Blind)	1-1/2	61.5
Double HD MAZE Asphalt & Fiberglass Shingle Nail	1-3/4	0.365	0.125	7/16 in. OSB	Sierra Premium or Savannah Smooth (Blind)	7/16	21.3
#8-18 ROCK-ON™ Screws	1-5/8	0.395	0.162	DF w/7/16 in. OSB	Sierra Premium or Savannah Smooth (Blind)	1-1/8	207.8
				7/16 in. OSB	Sierra Premium or Savannah Smooth (Blind)	7/16	80.8
#7 PrimeGuard SS Trim/Finish Grip Rite Screw	2.25	0.233	0.151	DF w/7/16 in. OSB	Sierra Premium or Savannah Smooth (Face)	1-1/4	215.2

Notes:

- DF (Douglas Fir) framing material is assumed to have a Specific Gravity of 0.5 or greater.
- OSB sheathing material is assumed to have a Specific Gravity of 0.5 or greater.
- Alternative fasteners must meet the minimum head and shank diameters listed in Table 6. The required length and withdrawal capacity shall be determined by the design professional of record in accordance with the requirements of Table 5.

**TABLE 7 – WIND SPEED SUMMARY TABLE FOR PRE-ENGINEERED METAL BUILDING (PEMB) INSTALLATION<sup>1,4,6,7,8</sup>**

Steel Siding Thickness	Adjusted Allowable Design Pressure <sup>5</sup> (psf)	Adjusted Load per Fastener (lbs)	Building Height (ft)	ASCE 7-05 Basic Wind Speed - 3s Gust <sup>2</sup> (mph) <sup>2</sup>			ASCE 7-10, -16, -22 Ultimate Wind Speed - 3s Gust <sup>3</sup> (mph)		
				Exp B	Exp C	Exp D	Exp B	Exp C	Exp D
24ga (0.0223")	-31.41	75.57	15	114	104	94	147	134	122
			20	114	101	92	147	130	119
			25	114	99	90	147	127	117
			30	114	97	89	147	125	115
			40	110	94	87	142	121	112
			50	106	92	--	137	118	--
			60	104	90	--	134	116	--
22ga (0.0286")	-39.29	94.54	15	128	116	105	165	150	136
			20	128	113	103	165	145	133
			25	128	110	101	165	142	130
			30	128	108	99	165	139	128
			40	123	105	97	158	135	125
			50	119	102	95	153	132	122
			60	116	101	93	150	130	121

Notes:

- Nichiha AWP may only be installed on vertical wall and tabulated values are only valid for PEMB installations over 22ga or 24ga 50ksi steel siding with #10-16x1 in. Pan Head S/D Screws and JEL777, 778, 787 & 788 Steel Clips. Fasteners shall be installed at each steel siding rib not to exceed 12 in. on center.
- ASCE 7-05 Basic Wind Speeds are based upon occupancy category II, a wind directionality factor (K<sub>d</sub>) equal to 0.85, an internal pressure coefficient (GC<sub>pi</sub>) equal to +/-0.18, and an external pressure coefficient (GC<sub>p</sub>) equal to -1.4. The effects of topographic features have not been considered and the wind speed has been limited to 170 mph.
- ASCE 7-10, -16, -22 Ultimate Wind Speeds are based upon wind directionality factor (K<sub>d</sub>) equal to 0.85, an internal pressure coefficient (GC<sub>pi</sub>) equal to +/-0.18, and an external pressure coefficient (GC<sub>p</sub>) equal to -1.4. Under ASCE 7-16 and -22, the wind speeds are based on K<sub>e</sub> = 1.0. The effects of topographic features have not been considered and the wind speed has been limited to 210 mph.
- The values in this table are based on testing per ASTM E330 and represent the allowable capacity of the siding to resist the wind pressures associated with the corresponding wind speed.
- Allowable design pressures in highlighted cells have been adjusted based on the listed allowable withdrawal capacity of the tested fastener.
- Framing and bracing are beyond the scope of this evaluation report.
- Deflection of the metal siding shall not exceed the limit of L/120.
- Refer to Figs. 1 through 6 for Nichiha Clip System Details.



Intertek

130 Derry Court • York • Pennsylvania • 17406  
[intertek.com/building](http://intertek.com/building)



PCA-101

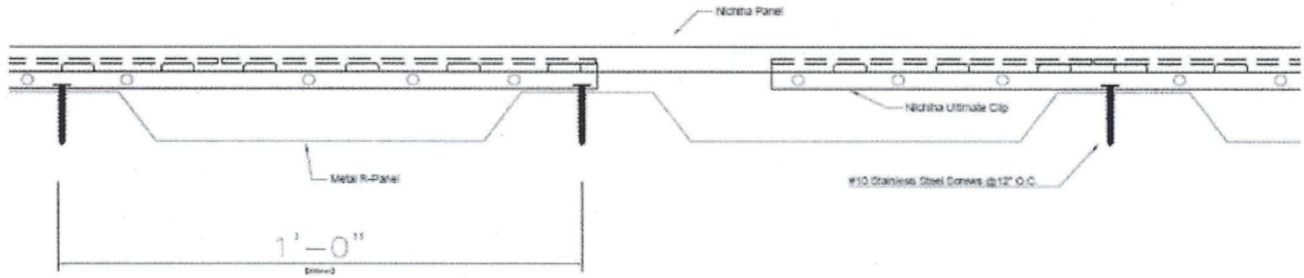
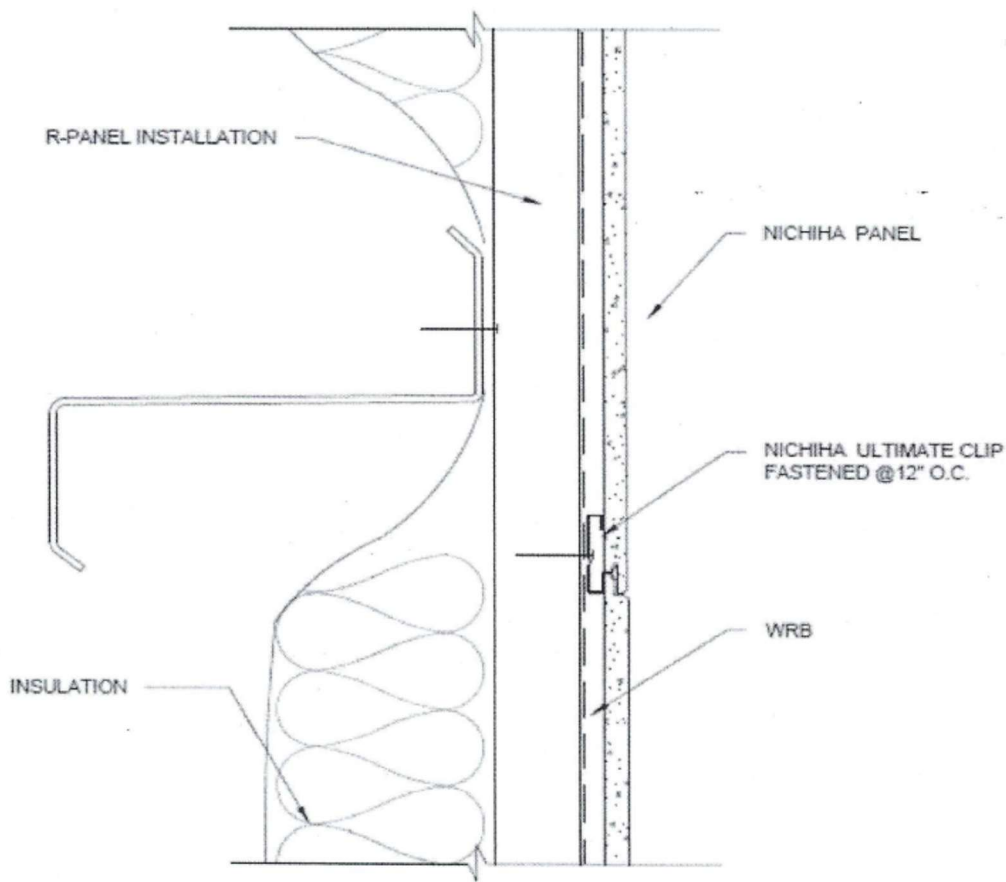

FIGURE 5 – TYPICAL INSTALLATION OVER PEMB METAL R-PANEL



PEMB PANEL- WALL SECTION

FIGURE 6 – TYPICAL PEMB PANEL WALL SECTION

**TABLE 8 – DESIGN LOADS FOR NEGATIVE TAS 202 AND TAS 203 TRANSVERSE LOAD  
(Florida Building Code – High Velocity Hurricane Zones)**

Siding Type and Nominal Thickness (in.)	Panel Orientation	Tested Framing Material <sup>5,7,8</sup>	Required Fastening Method	Fasteners and Fastening	Allowable Design Pressure (psf) <sup>5</sup>
Architectural Wall panel 5/8 in.	Horizontal	2 x 4 SPF Studs 16 in. oc 5/8 in. APA Plywood	JEL778/788 Steel Clip <sup>9</sup>	1-#10 x 1-1/4 in. long pan-head screw through plywood into each stud	-95 <sup>3</sup>
	Vertical <sup>2</sup>	2 x 4 SPF Studs 16 in. oc 5/8 in. APA Plywood	JEL778/788 Steel Clip <sup>9</sup>	4-#10 x 1-1/4 in. long pan-head screw per clip @ 6-1/2 in. oc to plywood only	-85 <sup>3</sup>
9 in. Sierra Premium Shake Lap Siding 1/2 in.	Horizontal	2 x 6 D.F. Studs 16 in. oc 5/8 in. APA Plywood	Blind	1 #7 Grip Rite PrimeGuard Max SS Screw <sup>6</sup> through top edge of plank through plywood into wood framing	-55 <sup>4</sup>
9 in. Sierra Premium Shake Lap Siding 1/2 in.	Horizontal	2 x 6 D.F. Studs 16 in. oc 5/8 in. APA Plywood	Face	1 #7 Grip Rite PrimeGuard Max SS Screw <sup>6</sup> through bottom edge of plank through plywood into wood framing	-110 <sup>4</sup>

## Notes:

1. Architectural Wall Panels, Sierra Premium Shake, and Savannah Smooth fiber-reinforced cement Lap Siding may only be installed on vertical walls.
2. Vertical panel installation is valid for 119-5/16 in. AWP 3030 product only.
3. Allowable pressures for 5/8 in. thick Architectural Wall panels may be used to validate installations of 3/4 in. and 7/8 in. thick panels installed with the same fastening/framing configuration shown in Table 8.
4. Allowable pressures shown for 9 in. Sierra Premium Shake may be used to validate installations of 6-1/4 in., 7-1/4 in., & 8-1/4 in. Savannah Smooth Lap Siding installed with the same fastening/framing configuration shown in Table 8.
5. The values in this table are based on testing per TAS 202 and TAS 203 and represent the allowable capacity of the siding to resist the specified wind pressures.
6. Fastener Head Diameter 0.232 in., shank diameter 0.118 in., and length of 2-1/4 in. These specifications may be used by the designer of record to determine the acceptability of alternative fasteners.
7. Framing and bracing are beyond the scope of this evaluation report.
8. DF (Douglas Fir) framing material.
9. Refer to Figs. 1 through 4 for Nichiha Clip System Details.
10. High Velocity Hurricane Zones are defined in Section 202 of the FBC as Dade and Broward Counties.



Intertek

130 Derry Court • York • Pennsylvania • 17406  
[intertek.com/building](http://intertek.com/building)



PCA-101